

Kidde Fire Systems Component Description



1.5" Valve Rebuild Kit

Effective: April 2023
K-85-3501 Rev AD

FEATURES

- For Approvals, see the "Compatibility" table.
- REACH and RoHS compliant

P/N 90-140100-000

ORDER INFORMATION

Note: The following Re-build Kit (P/N 90-140100-000) outlined in the table below shall be used to re-condition the valve:

Part Number	Description
90-140100-000	Kit, 1-1/2" Valve re-build. Includes 1 of each of the following: <ul style="list-style-type: none">• Safety Disc (1-1/2" Valve)• Washer, Safety Disc - 1-1/2" Valve• Nut, Safety Disc (1-1/2 - 2-1/2 Vlv) Retainer• O-Ring, Cap (1-1/2" valve)• O-Ring, Piston (1-1/2" valve)• Teflon™ Back-Up Ring, Piston (1-1/2" valve)• O-Ring, Seat (1-1/2" valve)• O-Ring, Cylinder Neck (1-1/2" valve)

COMPATIBILITY

Series	DIOM P/N	Approvals
Kidde Fire Systems ECS-500™ System	06-237585-001	UL, ULC, FM
Kidde Fire Systems ECS-500™ Marine System	06-237589-001	UL, ULC, USCG
Kidde Fire Systems ECS™ 360 for use with Fluoroketone Fire Suppression Agents	06-236553-001	UL, ULC, FM
Kidde Fire Systems ECS™ 360 Marine for use with Fluoroketone Fire Suppression Agents	06-236559-001	UL, ULC, USCG
Kidde Fire Systems ECS™ 360 with HFC-227ea Agent	06-236115-001	UL, ULC, FM
Kidde Fire Systems Modular ECS™ 360 with HFC-227ea Agent	06-236116-001	UL, ULC, FM
Kidde Fire Systems ECS™ 360 Marine with HFC-227ea Agent	06-236225-001	UL, USCG

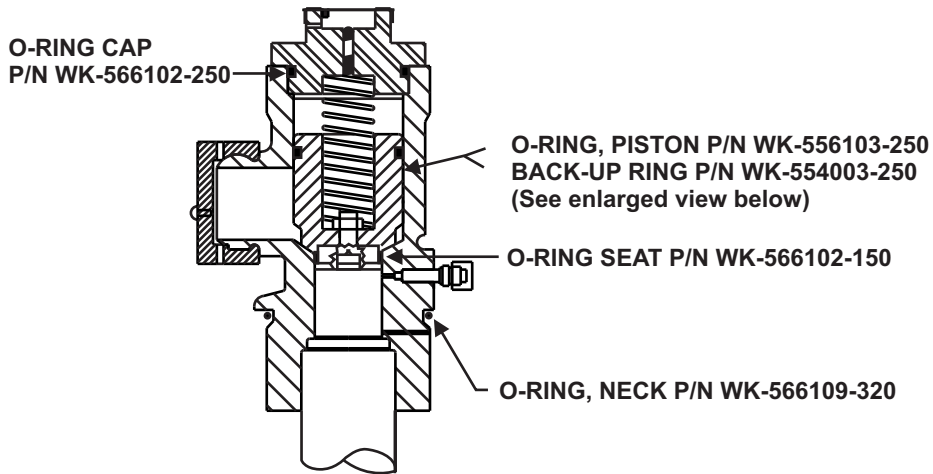
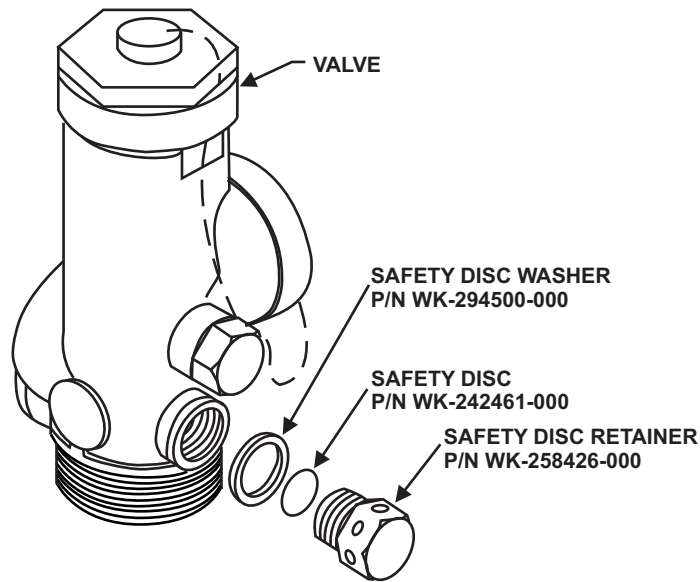

EXPORT INFORMATION (USA)

Jurisdiction: EAR

Classification: EAR99

This document contains technical data subject to the EAR.

All trademarks are the property of their respective owners.

This literature is provided for informational purposes only. KIDDE-FENWAL, INC. believes this data to be accurate, but it is published and presented without any guarantee or warranty whatsoever. KIDDE-FENWAL, INC. assumes no responsibility for the product's suitability for a particular application. The fire suppression system design, installation, maintenance, service and troubleshooting must be performed by trained, authorized Kidde Fire Systems distributors for the product to work correctly. If you need more information on this product, or if you have a particular problem or question, contact: KIDDE-FENWAL, INC., Ashland, MA 01721 USA, Telephone: (508) 881-2000.